



AHL-LIGHT 15

LED DROP LIGHT

AHL-LIGHT 15 is a small light that can illuminate narrow working areas.

APPLICATIONS

- Underwater nuclear drop light
- Ideal for work in reactor and fuel pools
- Works together with a separate power supply unit

BENEFITS

- Low maintenance costs due to its long life-time
- 15 000 lumen light output
- FME approved design - no loose parts can enter the pool water

SPECIFICATIONS

Diameter	60 mm (2,4")
Height	207 mm (8,1")
Weight	1,2 kg (2,3 lbs)
Housing material	Anodized aluminum
Backside material	Stainless steel
Front glass material	PUR
Maximum temperature	50°C, 70°C for short periods (122°F, 158°F)
Maximum cable length	up to 100m
Water tightness	6 bar (60 m)
Lights	LED 100-240 VAC, 50/60 HZ
Typical luminous flux	15 000 lumen
Life time	>50 000 h
Radiation tolerance (total dose)	50 000 Gy (5 000 000 rad)

We reserve the right to alter specifications without prior notice

AHL-LIGHT 15 IMAGES

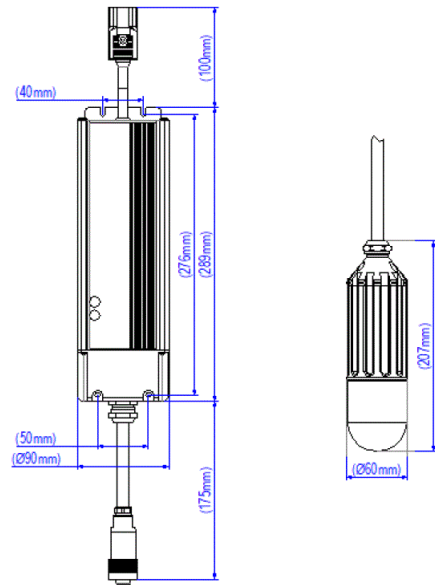

LINKS

 English

ahlbergcameras.staging.westart.se/products/lights/ahl-light-15

We reserve the right to alter specifications without prior notice