

P270

PAN UNIT

P270 is mostly used as pan unit in 4-face fuel inspection installations.

APPLICATIONS

- For use in 4-face fuel inspection installations or similar applications

BENEFITS

- High radiation tolerance
- Robust design
- Working pan angles preset

SPECIFICATIONS

Length	140 mm (5,5")
Width	150 mm (5,9")
Height	40 mm (1,6")
Housing material	Stainless steel EN 1.4301 AISI 304 or anodised aluminum
Weight	2,7 kg (Aluminum) (5,8 lbs)
Maximum temperature	70°C (158°F)
Water tightness	IP68, min 3,5 bar (35 m)
Pan angle	360°
Radiation tolerance (total dose)	1 000 000 Gy (100 000 000 rad)

We reserve the right to alter specifications without prior notice

P270 IMAGES

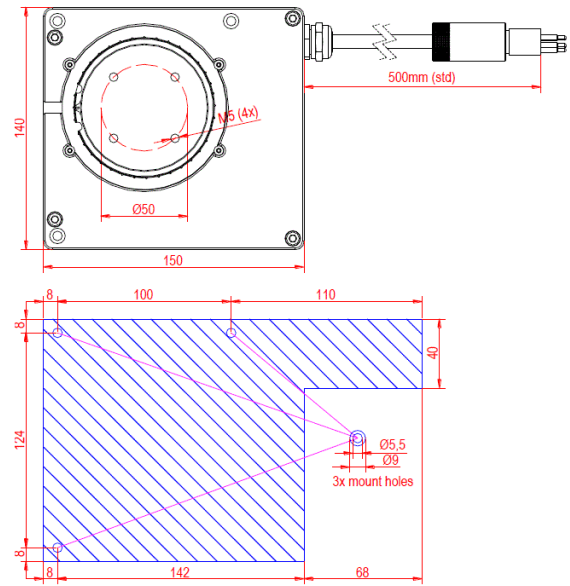
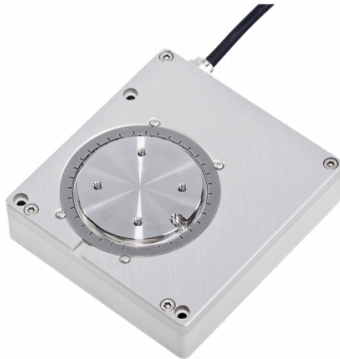

LINKS

 English

ahlbergcameras.staging.westart.se/products/accessories/p270

We reserve the right to alter specifications without prior notice